

MA40H1S-R

ULTRASONIC TRANSDUCER SMD Type

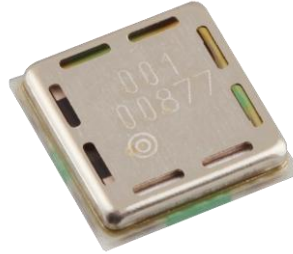

Features

- Small (5.2mm x 5.2mm)
- Thin (Thickness 1.15mm)
- Surface mount available
(solder-mount by reflow)
- No water proof
(possible by housing component)

Applications

- Distance measuring
- Object detection

Overview

MA40H1S-R is an ultrasonic transducer. MA40H1S-R transmits ultrasonic waves to the air and receives ultrasonic waves by one transducer. It is used to detect an object or distance to target by traveling time of reflected sound.

MA40H1S-R enables us to mount on narrow space or improve design by its features. For example, small(5.2mm x 5.2mm), thin(thickness 1.15mm) surface mount available and so on.

MA40H1S-R cannot be used in outdoor applications because it is open type structure.

And it cannot be used for automotive applications. We can support only for consumer application.

Attention:

This datasheet is downloaded from the website of Murata Manufacturing Co., Ltd.
Therefore, it's specifications are subject to change or our products in it may be discontinued without advance notice.
Please check with our sales representatives or product engineers before ordering.

TABLE OF CONTENT

1. Introduction	1
2. Usage of ultrasonic transducer	3
2.1 Measuring distance	
2.2 Object detection	
2.3 Ringing(Decay time)	
2.4 Resolution	
2.5 Circuit example	
3. Measurement details	8
4. FAQ	11
4.1 Characteristics	
4.2 Quality / Reliability	
4.3 Mounting	

Attention:

This datasheet is downloaded from the website of Murata Manufacturing Co., Ltd.
Therefore, it's specifications are subject to change or our products in it may be discontinued without advance notice.
Please check with our sales representatives or product engineers before ordering.

2. Usage of ultrasonic transducer

2.1 Measuring distance

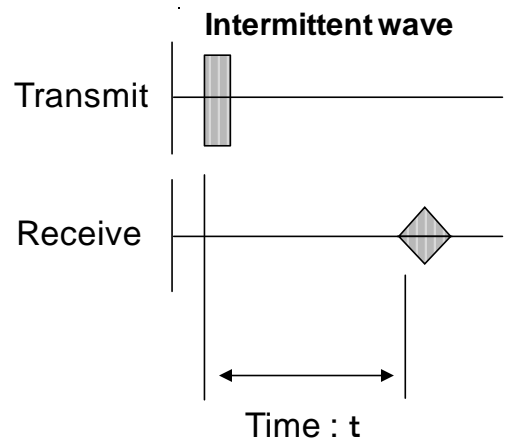
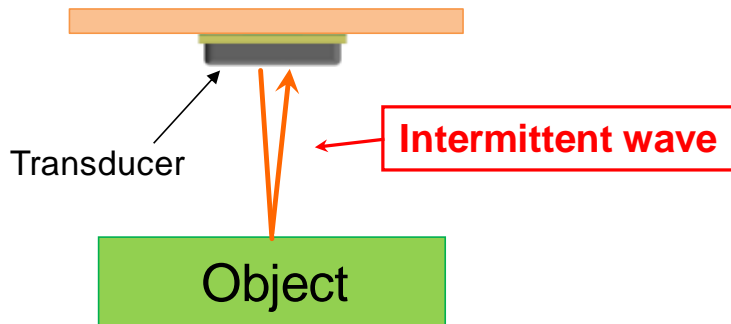

Measuring the time from transmitting to receiving (using clock)

$$\text{Time} \times \text{Sonic speed}(340\text{m/s}) / 2 = \text{Distance to the object}$$

2.2 Object detection

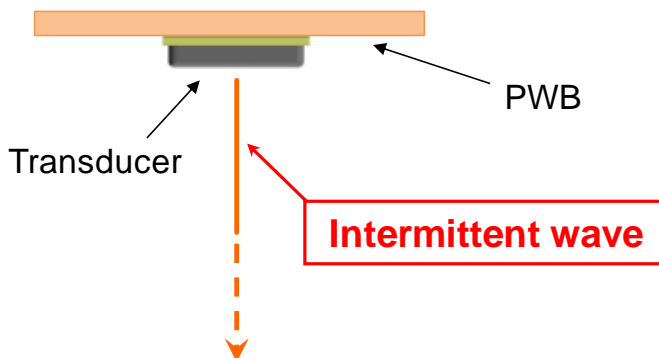

Received signal will not appear in the case that no object reflects the wave.

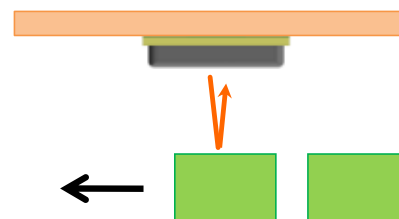

Smaller distance between sensor and object make signal bigger.

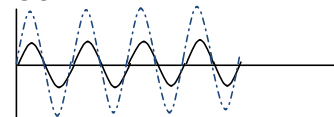

Attention:

This datasheet is downloaded from the website of Murata Manufacturing Co., Ltd. Therefore, it's specifications are subject to change or our products in it may be discontinued without advance notice. Please check with our sales representatives or product engineers before ordering.

2.3 Ringing(Decay time)

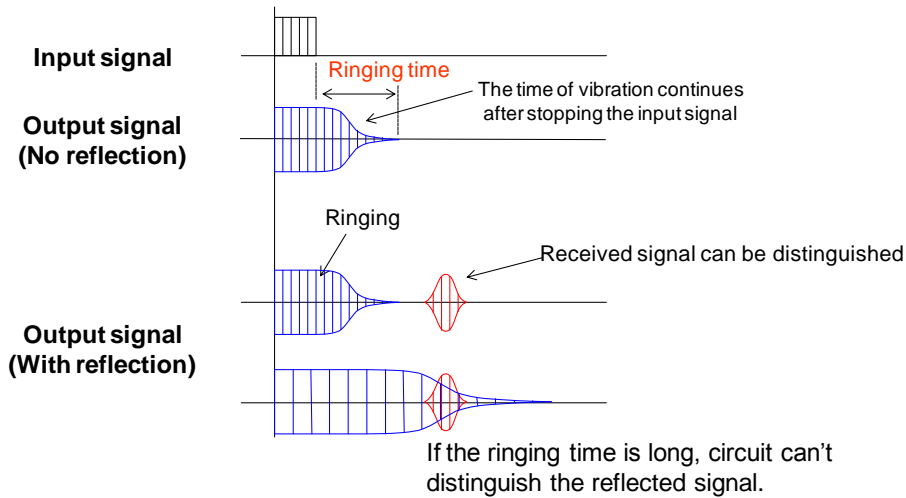

2.4 Resolution

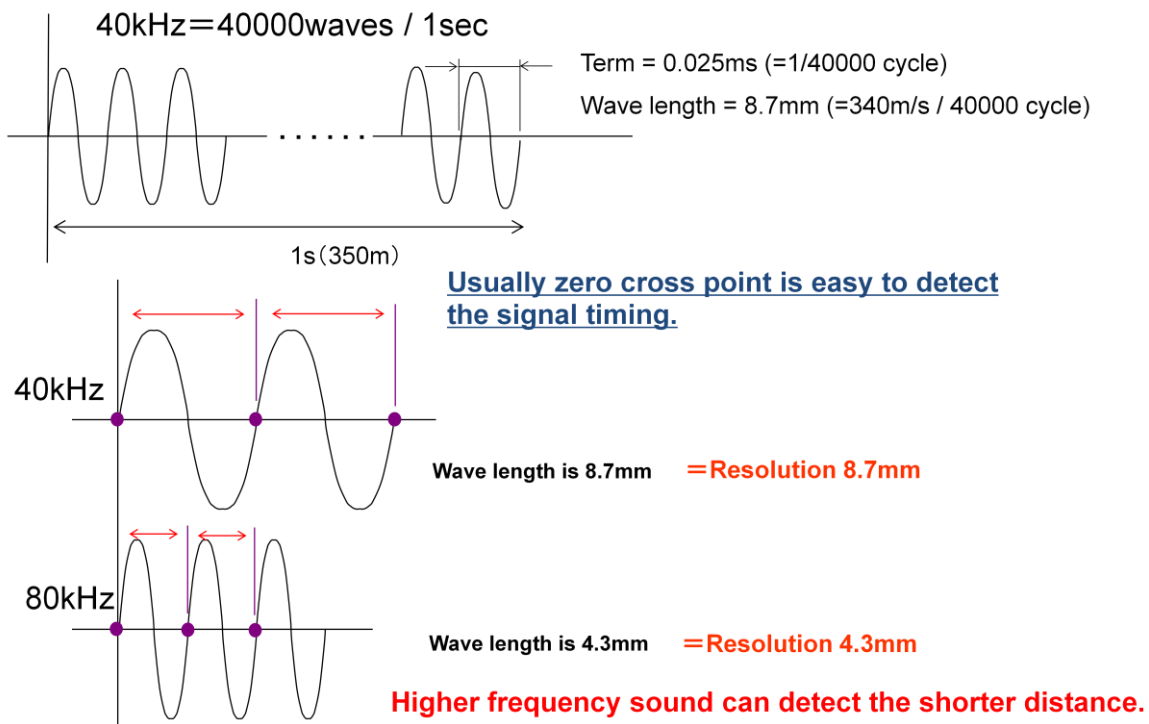

Attention:

This datasheet is downloaded from the website of Murata Manufacturing Co., Ltd. Therefore, it's specifications are subject to change or our products in it may be discontinued without advance notice. Please check with our sales representatives or product engineers before ordering.

Actually in the signal processing, the sensor recognizes the received wave which exceeds threshold point. And then the circuit calculates the distance with reference clock.

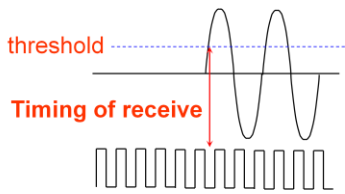

Count the clock pulse from the start of transmission to receive signal.

Distance is calculated as below example.

Ex:) Receive the signal after clock counts 150 pulses.
Clock cycle = 0.01ms

$$0.01/1000(\text{s}) \times 150(\text{counts}) \times 340(\text{m/s}) = 510\text{mm} = 51\text{cm}$$

However...

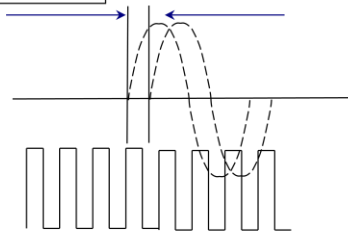

Even though the timing of received signal changes, if the number of clock pulse doesn't change, the circuit will distinguish as the same distance.

Thus, the resolution of measuring distance also depends on the frequency of clock pulse.

Attention:

This datasheet is downloaded from the website of Murata Manufacturing Co., Ltd. Therefore, it's specifications are subject to change or our products in it may be discontinued without advance notice. Please check with our sales representatives or product engineers before ordering.

2.5 Circuit example

Distance detection

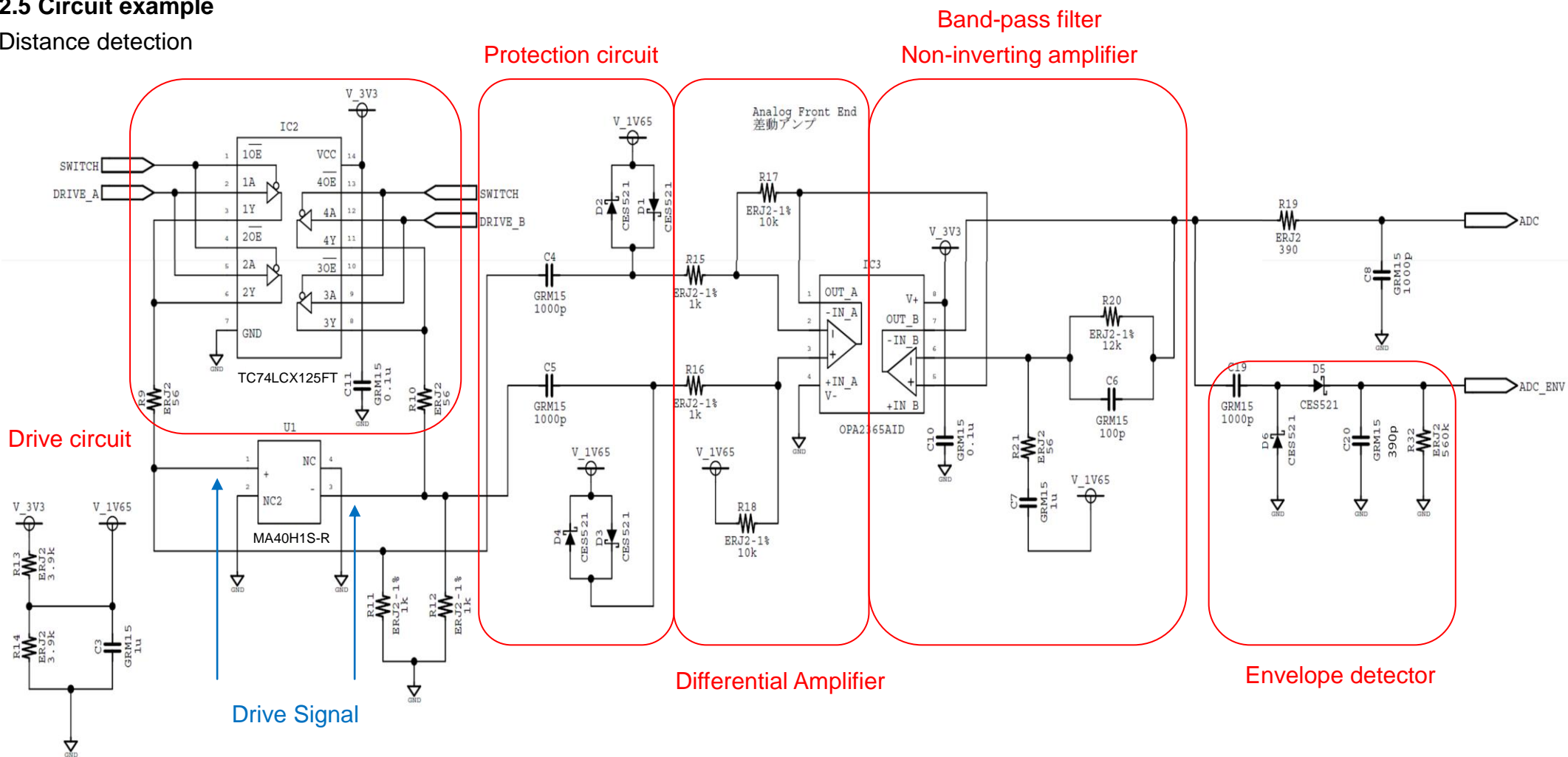

Attention:
This datasheet is downloaded from the website of Murata Manufacturing Co., Ltd.
Therefore, its specifications are subject to change or our products in it may be discontinued without advance notice.
Please check with our sales representatives or product engineers before ordering.

2.5.1 Time chart (reference)

Input signals

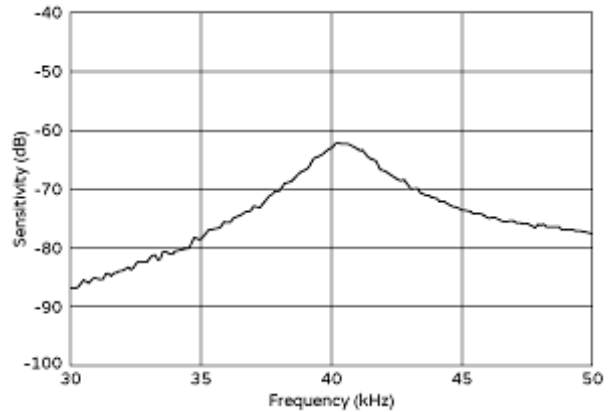
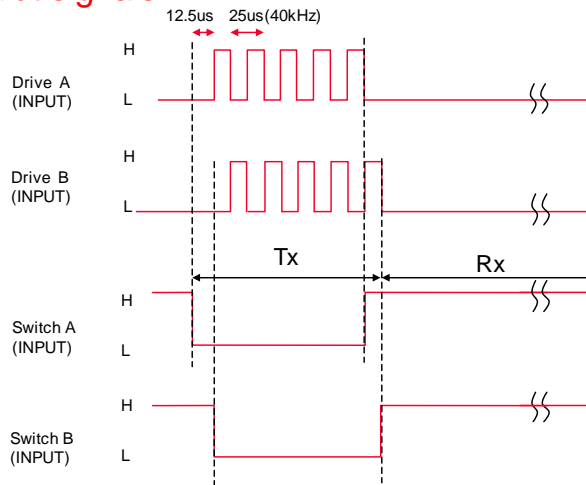

Drive signals

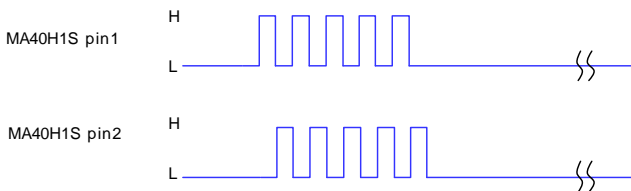

2.5.2 Time chart (Calculation of the period)

Input signals

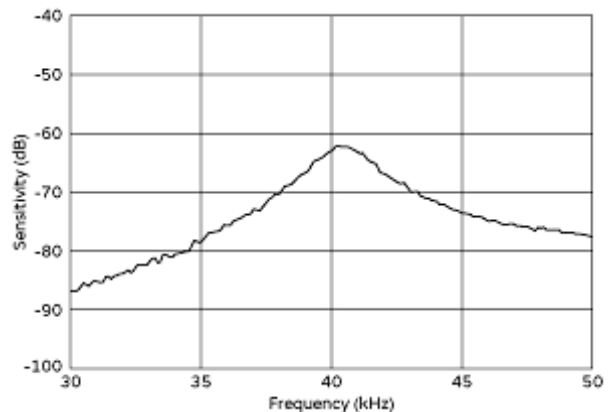
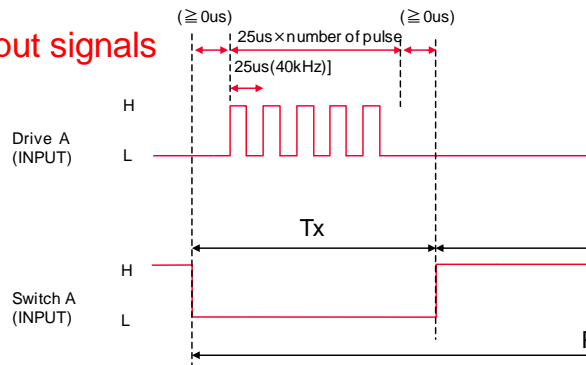

Period formula (in reflection)

$$l[m] = \frac{c[m/s] \cdot t[sec]}{2} \rightarrow \text{Period [m]}$$

$l[m]$: set the maximum rang of dista
(Since there is a possibility that the received by the next period)

Attention:

This datasheet is downloaded from the website of Murata Manufacturing Co., Ltd. Therefore, it's specifications are subject to change or our products in it may be discontinued without advance notice. Please check with our sales representatives or product engineers before ordering.

2.5.3 Time chart (Calculation of the distance)

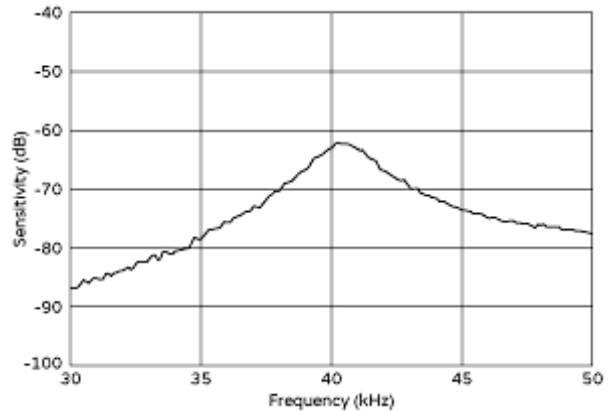
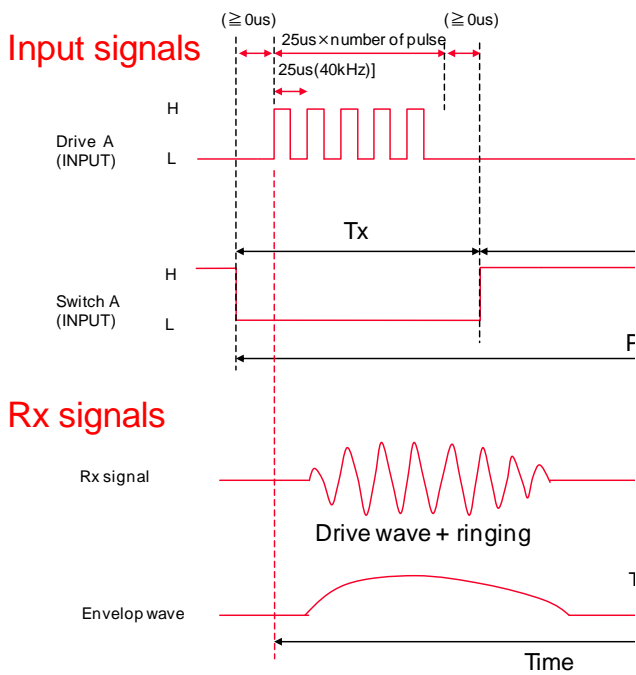

Distance formula (in reflection)

$$l [m] = \frac{c [m/s] \cdot Time [sec]}{2}$$

3. Measurement details

3.1 Impedance curve

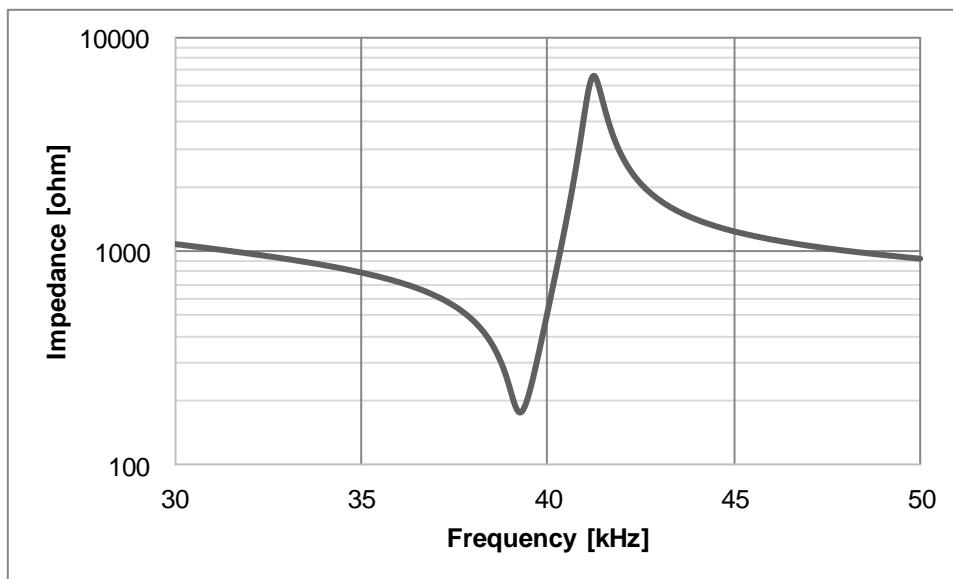

Attention:

This datasheet is downloaded from the website of Murata Manufacturing Co., Ltd. Therefore, its specifications are subject to change or our products in it may be discontinued without advance notice. Please check with our sales representatives or product engineers before ordering.

3.2 Equivalent circuit

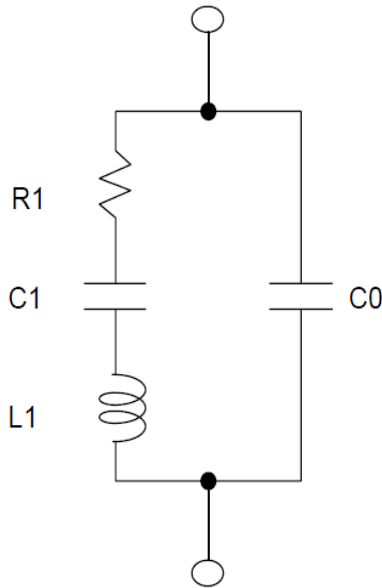

R1 : Resonant resistance(Serial resistance)

C1 : Serial capacitance

L1 : Serial inductance

C0 : Parallel capacitance

Input voltage [Vpp]	C0 [pF]	C1 [pF]	L1 [mH]	R1 [ohm]
0.5	4392	472	38	643
1	4369	462	39	633
2	4373	459	39	613
4	4373	439	40	598
5	4359	433	41	596
6	4356	428	41	576

3.3 S.P.L.

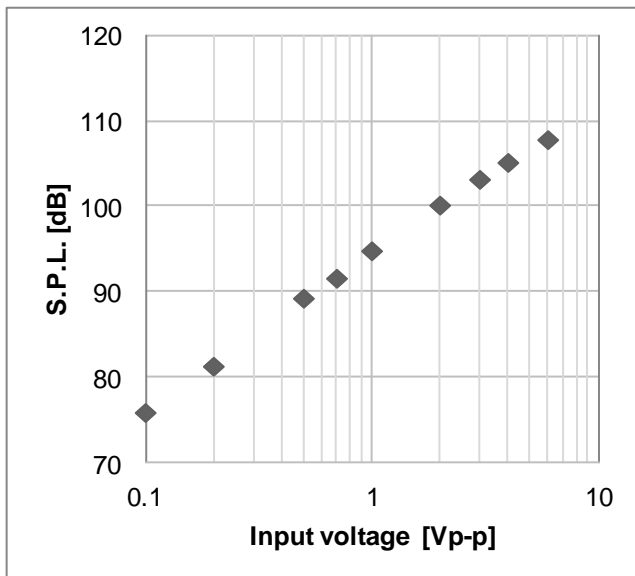

Input voltage vs S.P.L.
(40kHz, sin wave)

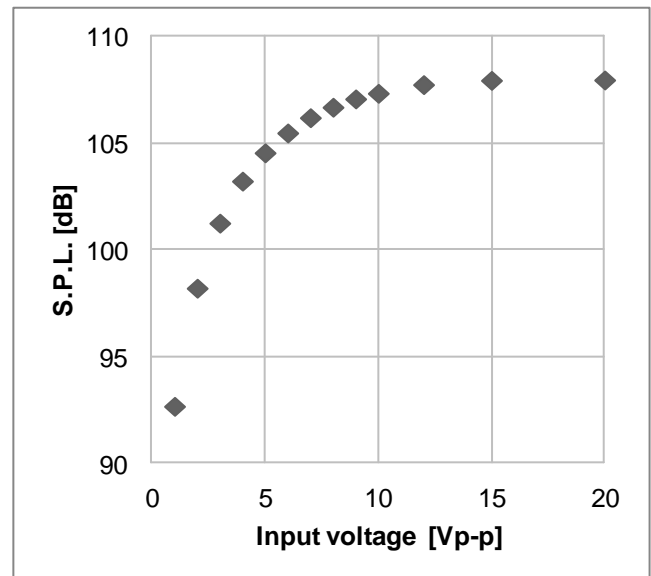

Number of burst vs S.P.L.
(40kHz, 6Vp-p burst)

Attention:

This datasheet is downloaded from the website of Murata Manufacturing Co., Ltd. Therefore, it's specifications are subject to change or our products in it may be discontinued without advance notice. Please check with our sales representatives or product engineers before ordering.

3.4 Detection range

Object	Min	Max
Wall	20cm	400cm
Human	20cm	200cm

*measurement in the front and optimized condition

	Easy to detect (Reflection intensity is high.)	Difficult to detect (Reflection intensity is law.)
Size	Large	Small
Shape	Flat	Round
Surface	Hard and Smooth (easy to reflect sound wave)	Soft (easy to absorb sound wave)

3.5 Directivity(With horn)

1. Open

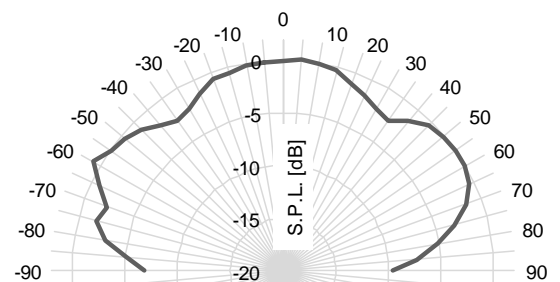
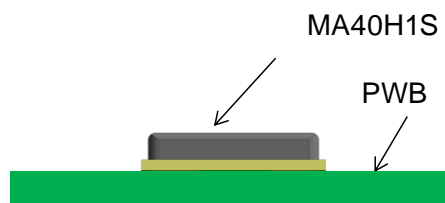

2. Flat plate

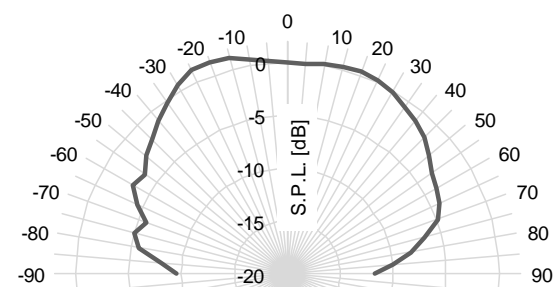
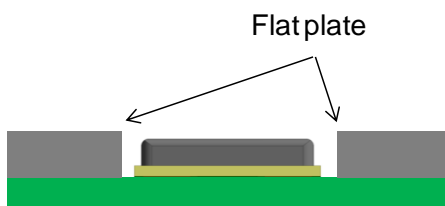

Attention:

This datasheet is downloaded from the website of Murata Manufacturing Co., Ltd. Therefore, it's specifications are subject to change or our products in it may be discontinued without advance notice. Please check with our sales representatives or product engineers before ordering.

3. Standard horn

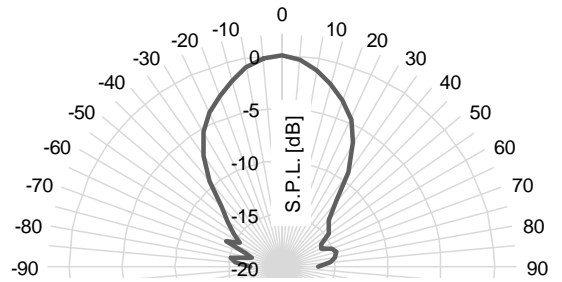
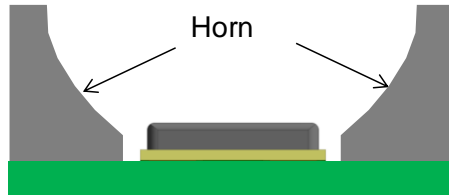

Horn dimension(reference)

Top view

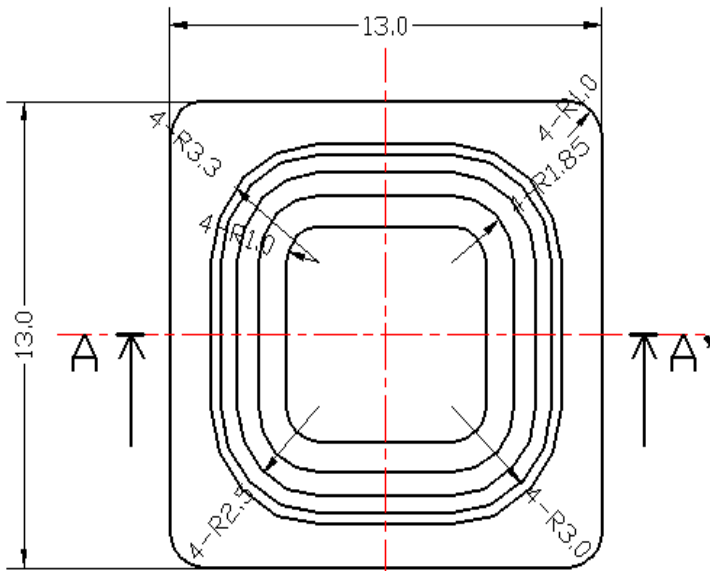

Appearance



A-A' cross section

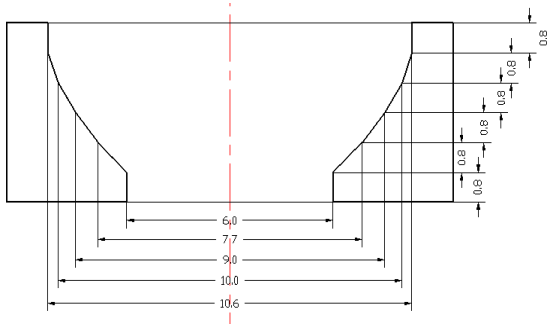

Attention:

This datasheet is downloaded from the website of Murata Manufacturing Co., Ltd. Therefore, its specifications are subject to change or our products in it may be discontinued without advance notice. Please check with our sales representatives or product engineers before ordering.

4. FAQ

4.1 Characteristics

What are Decay time?

Generally, a "Decay time" refers to a sound generated by the oscillator during damped oscillation after the drive signal is switched off. For practical purposes, the decay time of an ultrasonic sensor is defined as the time it takes the oscillator to be damped to a certain reference voltage(refer to 1.4).

Is it possible to make the sensor directive by an electrical means?

It is difficult to electrically control the beam pattern of Murata ultrasonic sensors. (With a sensor having broad resonance characteristics, it is possible to more or less control the beam pattern by changing the frequency of the drive signal. The drawback is that the broad resonance characteristics result in lower sound pressure.)

Is it possible to recognize the size and shape of the object detected?

It is difficult for Murata ultrasonic sensors to determine the size of the object. If multiple sensors are used in an array, we assume it is possible to determine object size from differences in echo arrival time at individual sensors, however this is unrealistic in terms of both technical and cost efficiency. (For recognition of plane surface size, it is far more inexpensive to use a CCD camera.) To recognize object size, it is necessary to use an array of sensors and intelligent image processing, as in ultrasonic diagnosis equipment for medical use. It is also necessary to limit the range of sensing reflections. Therefore we believe it is not a realistic solution to recognize object size using ultrasonic sensors.)

Is it possible to detect short distances?

It is possible to detect approximately 15cm by adjusting the drive voltage and the number of drive waves, but we believe it is difficult to detect approximately 10cm or less because the impact of reverberations cannot be eliminated entirely.

Are there ways to narrow directivity?

Attach a horn.(refer to 2)

Do the ultrasonic waves interfere with remote control communication using 40kHz waves?

Do they interfere only with sound waves?

Ultrasonic waves have no impact on electromagnetic waves. Note, however, that, if the 40kHz signal line runs in close vicinity of the ultrasonic sensor, noise from the signal line could be superimposed on the sensor signal, reducing the S/N ratio. Since the recipient sensor signal line has a high impedance, it is recommended that it be connected in the shortest possible length and shielded to minimize the impact of crosstalk and external noise.

Attention:

This datasheet is downloaded from the website of Murata Manufacturing Co., Ltd. Therefore, it's specifications are subject to change or our products in it may be discontinued without advance notice. Please check with our sales representatives or product engineers before ordering.

Is it possible to detect human bodies?

It is possible to detect areas that easily reflect sound waves, such as the face and hands. Clothes are difficult to sense because they absorb sounds. The difference from infrared sensors is that ultrasonic sensors can detect stationary objects and measure the distances to them.

Is it possible to detect an object that is placed behind a film?

It depends on the thickness of the film and the distance to the object. It may be possible if the film is thin enough for the ultrasonic wave to penetrate and the object is placed at a short distance.

What is the resolution limit?

(What is the size in mm for the steps of distance detection?)

Approximately 9mm
(1 wavelength of the 40kHz sound) under ideal conditions.

Is there any difference of Max Input Voltage between Open-Structure and SMD type?

Difference of Max Input Voltage is as follows;

- MA40S4S(Open):Square Wave, 40kHz, 10Vrms
- MA40H1S(SMD):Square Wave, 40kHz, 6Vpp

Can SMD type detect gesture?

It is difficult to detect gesture by MA40H1S-R.

4.2 Quality / Reliability

Can Murata ultrasonic sensors be used under water?

Murata ultrasonic sensors are designed for use in the air and not under water.

MA40H1S-R should not be used outdoors, either.

It cannot be used in environments where they are exposed to rain and/or dust.

Is it possible to prevent false detection of dirt and dust?

Foreign matter, such as snow or dirt, attached to the sensor surface inevitably causes false detection because it reflects sound waves. Dirt and dust covering the surface reduces sound pressure and changes sound distribution due to scattering. These problems inevitably affect the detection area. MA40H1S-R cannot be used in environments where water drops adhere to the sensor.

Attention:

This datasheet is downloaded from the website of Murata Manufacturing Co., Ltd.
Therefore, it's specifications are subject to change or our products in it may be discontinued without advance notice.
Please check with our sales representatives or product engineers before ordering.

Do Murata ultrasonic sensors cause health problems?

Do ultrasonic waves affect the health of the human body or animals (pets)?

There are no laws that regulate the “sound volume” of aerial ultrasonic waves. As a general guideline, it is reported that long exposure to ultrasounds of 105-115dB or more may cause buzzing in the ear and discomfort. It is recommended that the ultrasonic volume be kept below the above limit in the sensor range used.

4.3 Mounting

How can I use Murata ultrasonic sensors?

Murata ultrasonic sensors have no built-in circuits. Apply a drive signal (40kHz, AC) to your sensor. See the Application Manual for details.

Attention:

This datasheet is downloaded from the website of Murata Manufacturing Co., Ltd. Therefore, it's specifications are subject to change or our products in it may be discontinued without advance notice. Please check with our sales representatives or product engineers before ordering.